

CLEAN-ROLL®

HIGH PERFORMANCE ROLLING DOOR

The Only USDA-Compliant High-Speed Rolling Door.

The Clean-Roll door is the only high-speed roll door designed specifically to meet the most comprehensive and stringent hygienic standards in the world – a combination of USDA, FDA, NSF and ISO standards.

All of the door's components are fabricated of stainless steel or USDA compliant materials. Designed to allow complete washdown and includes many more sanitary design features that make it the natural choice for applications that demand absolute cleanliness. Plus, it provides all the low-maintenance, energy savings and productivity benefits of a high-speed door.



Sanitary Design - Classified by Underwriter's Laboratories (UL® 2128) to meet USDA hygienic standards for meat, poultry, dairy and seafood applications. The entire door is designed to be spray washed, yet its sanitary design prevents liquid contaminants from dripping into the traffic pathway and virtually eliminates potential sites for bacteria manifestation.

Takes a Hit - Clean-Set™, Break-Away™ tabs allow bottom bar to be reset in just seconds, without tools, virtually eliminating door downtime.

Energy Efficient - High speed operation conserves energy and maintains constant climate control while helping to minimize infiltration of airborne pathogens.

Safety - Pneumatic, dual-chamber reversing edge and thru-beam photo eyes. Optional full-width, heat-sealed window provides excellent visibility.

RYTEC
CORPORATION
Driving The Door Industry.™

CLEAN-ROLL®

HIGH PERFORMANCE ROLLING DOOR

Specifications: Subject to change

Model: Rytec® Clean-Roll® Door
UL® 2128 certified

Standard Size: Up to 12 feet wide by 12 feet high.

Door Panel: USDA and FDA compliant, white or blue panel material with optional heat sealed window.

Side Frames: Fully bolt together side frames made from 304 stainless, with 2B finish. Patented side column covers, made of 304 stainless steel with #4 finish, can be easily removed to facilitate cleaning. One set of NEMA 4X thru-beam electric photo eyes internally mounted in side frame, one set field-installed.

Optional Manual Release: Optional counterbalanced manual release system. Includes two counterweights and brake release.

Head Assembly: Patented stainless steel roll drum with stainless piano hinge to connect fabric. No excess fabric on drum when door is in the closed position, reducing bacteria build-up. Patented drum designed to rotate an additional 120° revolution to allow complete cleaning of drum and fabric. Patented drip guard shrouds the roll drum and panel material. Hinged drip guard lifts up to facilitate cleaning of drum and panel material. Drip guard's integrated gutter prevents liquid contaminants from dripping into traffic pathway.

Bottom Bar: Clean-Set, Break-Away tabs and stainless steel bottom bar release in either direction without damage to the door. Standard dual cut-off switches shut off motor when bottom bar is impacted. Pneumatic, dual-chamber reversing edge is standard. Patented, sloped bottom bar prevents liquid contaminants from dripping into traffic pathway. No exposed junction box on bottom bar.

Travel Speed: Opens at up to 50 inches per second.

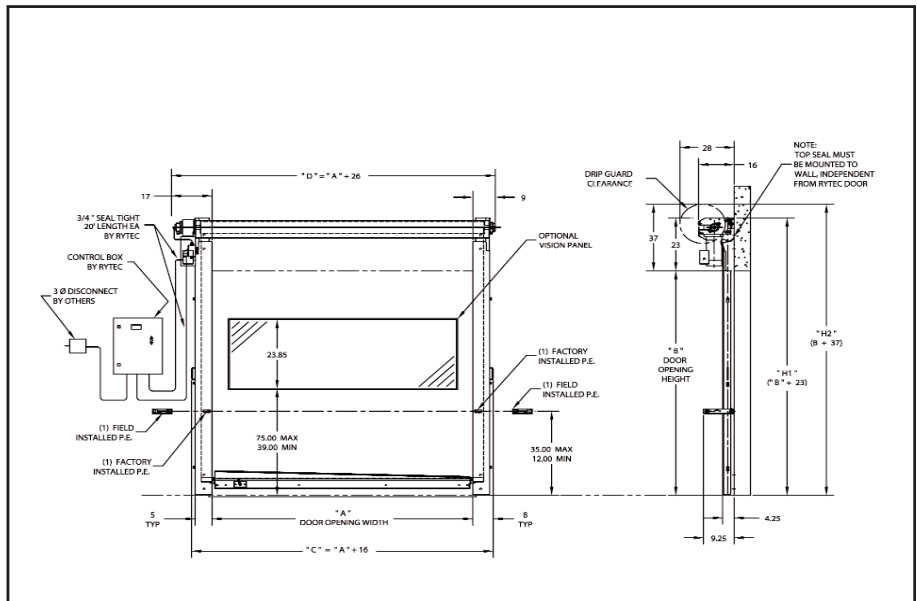

Patented, Sloped Gutter System

Prevents liquid contaminants from dripping into doorway.

Drive System: Three-phase, variable speed AC Drive with food-grade, washdown motor provides soft acceleration and deceleration. Independent opening and closing speeds provide flexibility to accommodate any application. Motor and electrical components are factory wired to junction boxes in the head assembly.

Electrical Controls: System 3 controller is housed in a NEMA 4 rated enclosure with factory set parameters. Self-diagnostic features and a two-line, 32-character LCD display in English, Spanish or French provide quick and straightforward installation and control adjustments. Programmable inputs and outputs accommodate special control requirements without the need for additional electrical components.

Warranty: One year limited warranty on materials and workmanship.



Reversing Edge

Pneumatic, dual-chamber reversing edge reverses the door upward upon contact with anything in its closing path.



Stainless Steel Side Columns

Patented covers are removable for easy, thorough washdown.



One Cedar Parkway
Jackson, WI 53037-0403
Phone: 262-677-9046
Fax: 262-677-2058
Toll Free: 888-GO-RYTEC
Email: info@rytecdoors.com
Web: www.rytecdoors.com