

PHARMA-SEAL®

HIGH PERFORMANCE ROLLING DOOR

The High-Speed Roll Door Engineered for cGMP and “Class-Rated” Facilities.

With input from pharmaceutical engineers in the United States and Europe, the Pharma-Seal is engineered to comply with cGMP guidelines, and to be the tightest sealing, most reliable, high performance rolling door available today. The Pharma-Seal's design eliminates external photo eyes, brackets and electrical coil cords. This fully enclosed door offers full stainless steel side columns and head assembly. The door incorporates the unique RyBeam™ light curtain safety system.

The Pharma-Seal door is engineered for high-cycle environments. Its simple design has no external parts. A flush membrane switch and flush manual release handle make it easy to clean. Designed to meet the requirements of cGMP facilities, the Pharma-Seal is engineered and manufactured to provide the reliability required for uninterrupted facility operations.

Shown with optional window and Pharma-Guard bollards.



Easy to Clean - Fully enclosed 304 or 316 stainless steel side and hood covers, and no windribs on curtain provide smooth, easy to clean surfaces.

Safety - The RyBeam light curtain covers the door opening up to 98 inches to meet OSHA requirements. The door reverses without physical contact providing unparalleled personnel and equipment safety.

Fast - Opens at up to 50 inches per second with an adjustable closing speed to meet your exact specifications.

Simple to Control - The System 3® controller features state-of-the-art motion control technology, as well as numerous easy programming options to meet your exact specifications. Absolute encoder eliminates mechanical limit switches.

Low Profile - The Pharma-Seal requires only 9 inches of side frame clearance and only 14 inches of head clearance.

Tight Seal - With only a 3/8-inch gap for the curtain, the hidden windknobs allow this door to be self-sealing around the entire perimeter.

Manual Release - If power is lost, simply pull the flush manual release handle to open the door.

RYTEC
CORPORATION
Driving The Door Industry.™

PHARMA-SEAL®

HIGH PERFORMANCE ROLLING DOOR

Specifications: Subject to change

Model: Rytec® Pharma-Seal® Door

Standard Size: Up to 10 feet wide by 10 feet high. Consult factory for special sizes.

Door Panel: USDA/FDA-compliant, 2-ply multifilament white or blue panel with wind tabs standard. No windribs needed. Optional heat-sealed, full-width PVC vision panel is easy to clean and provides excellent visibility. Easily withstands industry standard of 0.10 inches of water, with little to no air infiltration.

Head and Side Frames: Standard side frames are constructed of 304 stainless steel with a #4 finish. Optional 316 stainless steel is available. Fully-enclosed side frames are easy to clean and simple to remove. Only 9 inches of side frame clearance and 14 inches of head clearance required.

Bottom Bar: Stainless steel bottom bar with only a 3-inch profile height. Vinyl loop seal hugs the floor for a tight seal. No coil cord or other electronics in the bottom bar.

Door Safety: Patented RyBeam light curtain mounted in the door jamb provides coverage of the door opening up to 98". Persons or objects entering the opening will cause the door to reverse without contact.

Manual Release: Counterbalanced manual release system incorporates fully-enclosed springs and brake release allowing the door to open with the flip of a lever.

Head Assembly: Stainless steel hood fully encloses the head creating a seal at the top of the door, eliminating the need for a weather gasket that eventually can create particles in the air and on the floor.

Drive System: Three-phase, variable speed, AC Drive provides soft acceleration and deceleration. Independent opening and closing speeds provide flexibility to accommodate any application.

Travel Speed: Opens at up to 50 inches per second.

Warranty: One-year limited warranty on materials and workmanship.

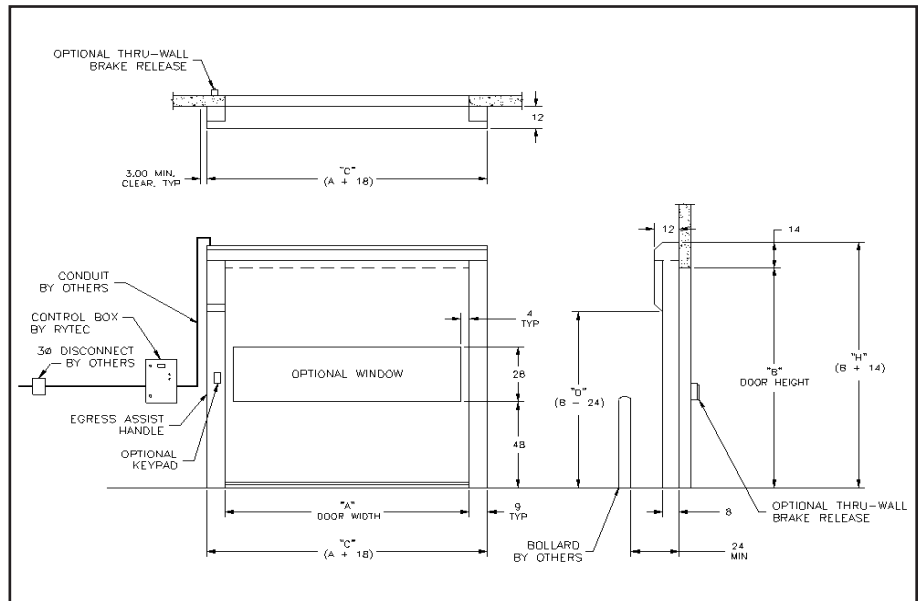

▲ **Flush Manual Release**

Flush manual release lever opens door in case of power loss.



▲ **Flush Membrane Switch**

Membrane switch allows controls to be remotely mounted.



▲ **Unique Light Curtain Safety System**

The RyBeam light curtain safety system, mounted and protected in the side guides, covers the door opening up to 98" to meet OSHA requirements.

Electrical Controls: System 3 controller is housed in a NEMA 4 rated enclosure with factory set parameters. Self-diagnostic features and a two-line, 32-character LCD display in English, Spanish or French provide quick and straightforward installation and control adjustments. Programmable inputs and outputs accommodate special control requirements, including interlocks, without the need for additional electrical components.

Stainless Steel Bollards: Optional Pharma-Guard™ seamless, stainless steel, bollards with sloped tops to minimize accumulation of contaminants are available.



One Cedar Parkway
Jackson, WI 53037-0403
Phone: 262-677-9046
Fax: 262-677-2058
Toll Free: 888-GO-RYTEC
Email: info@rytecdoors.com
Web: www.rytecdoors.com